

# NPA

New Product Announcement No. 2019-42



## DRILLSFEED

INDEXABLE 3 FLUTE

### Head Changeable 3-Flute Drill for Higher Productivity



## KEY POINT

**TaeguTec has introduced the DRILL-SFEED, a new head changeable 3-flute drill.**

TaeguTec's DRILLRUSH line, which has been meeting customer's needs with outstanding machining and convenience, has released a 3-flute drill with upgraded clamping structure designed to maximize productivity.

The **DRILL-SFEED** uses unique, self-centering features, unlike conventional 3-flute carbide drills, to ensure superior performance and machining stability in high-speed machining. It also provides optimal solutions for customers to reduce costs by improving tool life as well as achieving high productivity due to its strong cutting edges and the latest coating technology.

The original clamping structure allows for the simple replacement of drill heads, as well as varying sizes of heads onto a single tool body, thus facilitating economical end user drill stock management.

For further technical questions, please contact TaeguTec's product manager.

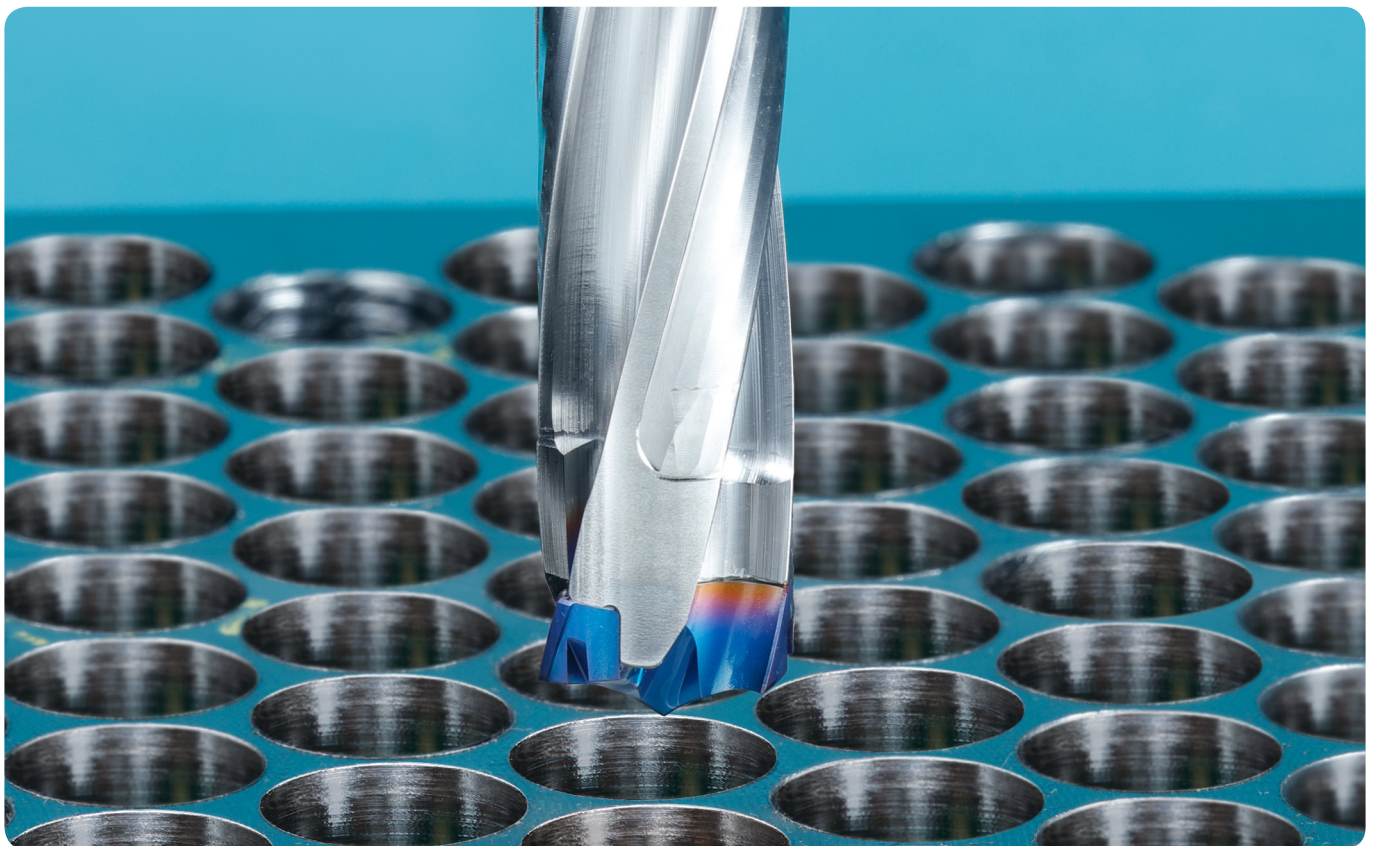

## Features

- 3-flute geometry improves productivity by more than 50%
- Highest machining stability due to its unique edge geometry
  - Excellent hole precision due to its superior self-centering capability
  - Reduced cutting load
  - Internal coolant through type means smooth chip evacuation
- The latest coating grade for excellent tool life
- Simplified drill head exchanging for reduced downtime
- Suitable for steel and cast iron machining
- Drill diameter range: 16.0 - 20.5 mm (3xD and 5xD)

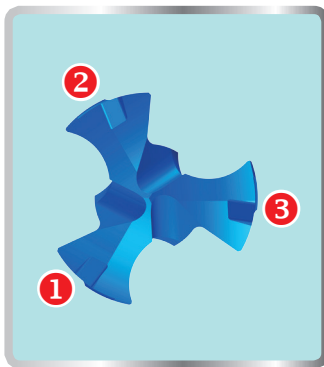

## Availability

In stock

## Price

Available in the GAL system

Sincerely,  
 TaeguTec

**Sung Chang-ho**  
 Hole-Making General PM

## Case study 1

	TaeguTec	TaeguTec
Material	Alloy steel (AISI 4140)	
Drill	TCD 160-169-20T3-5D	3ED 160-169-20T3-5D
Head	TCD-160-P TT9080	3ED-160-P+ TT5130
Drilling depth (mm)	80 (Through hole)	80 (Through hole)
Cutting speed   V (m/min)	100	100
Feed   f (mm/rev)	0.45	0.45
Coolant	Internal (15 bar)	Internal (15 bar)
Tool life (holes)	910/840	1,330/1,190

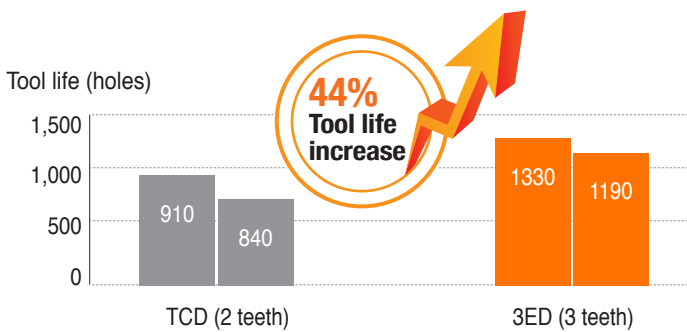

## Case study 2

	TaeguTec	TaeguTec
Material	Cast iron (DIN GG 30)	
Drill	TCD 160-169-20T3-5D	3ED 160-169-20T3-5D
Head	TCD-160-K TT9080	3ED-160-P+ TT5130
Drilling depth (mm)	50 (Through hole)	50 (Through hole)
Cutting speed   V (m/min)	160	160
Feed   f (mm/rev)	0.6	0.6
Coolant	Internal (15 bar)	Internal (15 bar)
Tool life (holes)	720/800	1,760/1,700

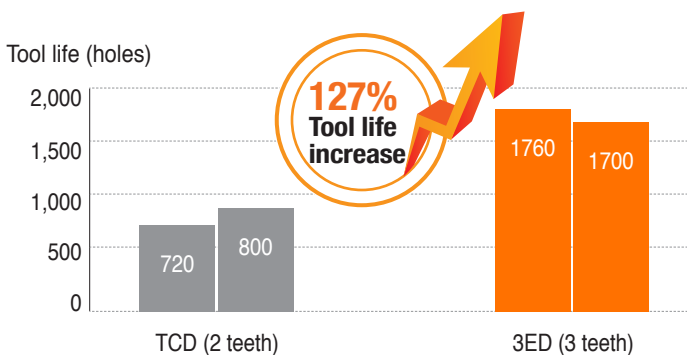

## 3ED...T...-3D



### Head changeable 3-flute drill holders - Weldon type shank



- Drilling depth: 3xdiameter

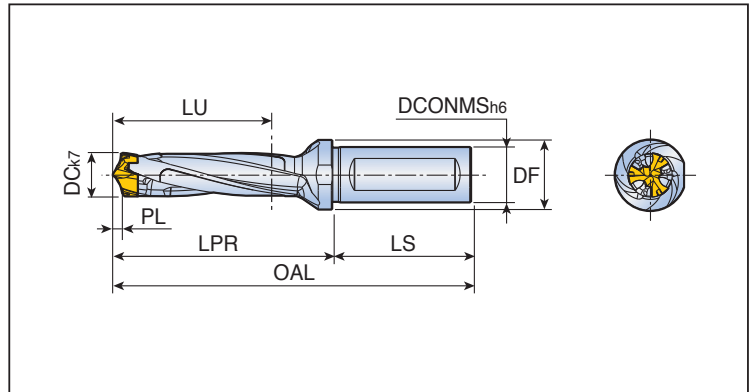

Designation	Dimension (mm)								Clamping key
	DC	DCONMS	DF	LU	LPR	LS	PL	SSC	
<b>3ED 160-169-20T3-3D</b>	16.0-16.9	20	25	52	79.0	50	3.70	16	K 3ED D16-D17
<b>170-179-20T3-3D</b>	17.0-17.9	20	25	55	84.0	50	3.88	17	K 3ED D16-D17
<b>180-189-25T2-3D</b>	18.0-18.9	25	32	58	90.1	56	4.07	18	K 3ED D18-D19
<b>190-199-25T2-3D</b>	19.0-19.9	25	32	61	94.7	56	4.26	19	K 3ED D18-D19
<b>200-209-25T2-3D</b>	20.0-20.9	25	32	64	99.3	56	4.44	20	K 3ED D20-D21

## 3ED...T...-5D



### Head changeable 3-flute drill holders - Weldon type shank



- Drilling depth: 5xdiameter

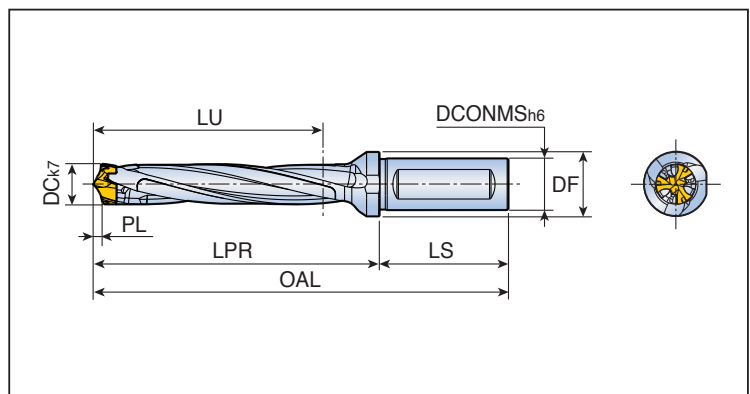

Designation	Dimension (mm)								Clamping key
	DC	DCONMS	DF	LU	LPR	LS	PL	SSC	
<b>3ED 160-169-20T3-5D</b>	16.0-16.9	20	25	84	111.0	50	3.70	16	K 3ED D16-D17
<b>170-179-20T3-5D</b>	17.0-17.9	20	25	89	118.0	50	3.88	17	K 3ED D16-D17
<b>180-189-25T2-5D</b>	18.0-18.9	25	32	94	126.1	56	4.07	18	K 3ED D18-D19
<b>190-199-25T2-5D</b>	19.0-19.9	25	32	99	132.7	56	4.26	19	K 3ED D18-D19
<b>200-209-25T2-5D</b>	20.0-20.9	25	32	104	139.3	56	4.44	20	K 3ED D20-D21

- OAL= LPR+LS
- SSC: Seat size code

## 3ED...T0...-3D



### Head changeable 3-flute drill holders - Cylindrical type shank



- Drilling depth: 3xdiameter

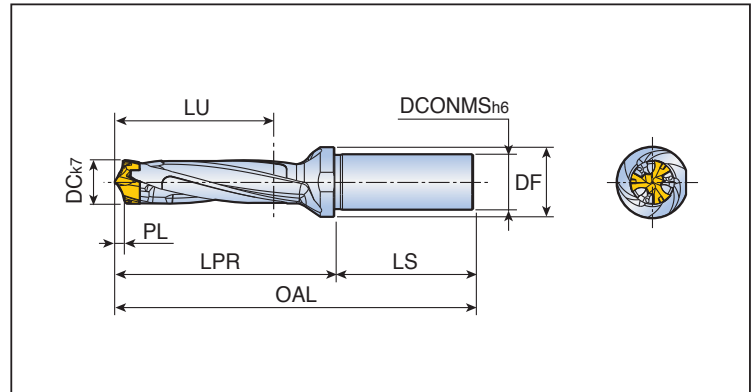

Designation	Dimension (mm)								Clamping key
	DC	DCONMS	DF	LU	LPR	LS	PL	SSC	
<b>3ED 160-169-20T0-3D</b>	16.0-16.9	20	25	52	79.0	50	3.70	16	K 3ED D16-D17
<b>170-179-20T0-3D</b>	17.0-17.9	20	25	55	84.0	50	3.88	17	K 3ED D16-D17
<b>180-189-25T0-3D</b>	18.0-18.9	25	32	58	90.1	56	4.07	18	K 3ED D18-D19
<b>190-199-25T0-3D</b>	19.0-19.9	25	32	61	94.7	56	4.26	19	K 3ED D18-D19
<b>200-209-25T0-3D</b>	20.0-20.9	25	32	64	99.3	56	4.44	20	K 3ED D20-D21

## 3ED...T0...-5D



### Head changeable 3-flute drill holders - Cylindrical type shank



- Drilling depth: 5xdiameter

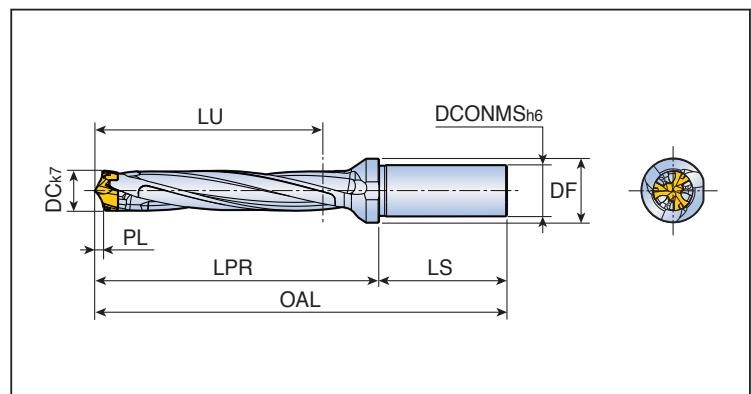

Designation	Dimension (mm)								Clamping key
	DC	DCONMS	DF	LU	LPR	LS	PL	SSC	
<b>3ED 160-169-20T0-5D</b>	16.0-16.9	20	25	84	111.0	50	3.70	16	K 3ED D16-D17
<b>170-179-20T0-5D</b>	17.0-17.9	20	25	89	118.0	50	3.88	17	K 3ED D16-D17
<b>180-189-25T0-5D</b>	18.0-18.9	25	32	94	126.1	56	4.07	18	K 3ED D18-D19
<b>190-199-25T0-5D</b>	19.0-19.9	25	32	99	132.7	56	4.26	19	K 3ED D18-D19
<b>200-209-25T0-5D</b>	20.0-20.9	25	32	104	139.3	56	4.44	20	K 3ED D20-D21

- OAL= LPR+LS
- SSC: Seat size code

## 3ED...-P+



### 3-flute drill heads

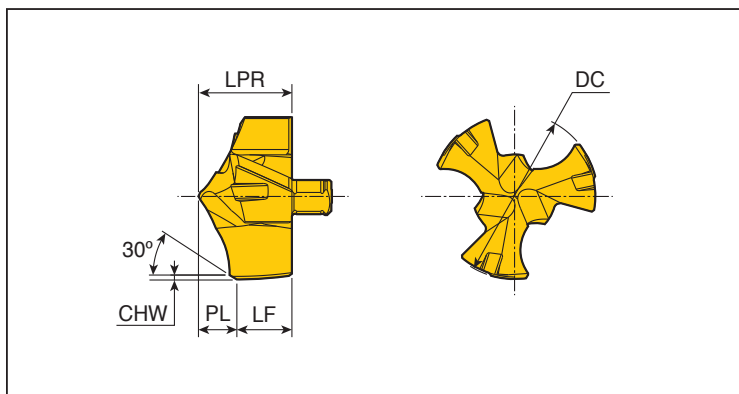

Designation	Dimension (mm)						Grade
	DC	LPR	PL	LF	CHW	SSC	TT5130
<b>3ED- 160-P+</b>	16.0	9.00	3.70	5.30	0.40	16	●
<b>165-P+</b>	16.5	9.00	3.71	5.29	0.40	16	●
<b>170-P+</b>	17.0	9.50	3.88	5.62	0.40	17	●
<b>175-P+</b>	17.5	9.50	3.89	5.61	0.40	17	●
<b>180-P+</b>	18.0	10.10	4.07	6.03	0.40	18	●
<b>185-P+</b>	18.5	10.10	4.08	6.02	0.40	18	●
<b>190-P+</b>	19.0	10.70	4.26	6.44	0.40	19	●
<b>195-P+</b>	19.5	10.70	4.27	6.43	0.40	19	●
<b>200-P+</b>	20.0	11.30	4.44	6.86	0.40	20	●
<b>205-P+</b>	20.5	11.30	4.45	6.85	0.40	20	●

● SSC: Seat size code

●: Standard items

## Recommended Cutting Conditions

ISO	Material	Condition	Material Example (JIS)	Tensile Strength (N/mm <sup>2</sup> )	Hardness HB	Material Group No	Cutting Speed Vc (m/min)	Feed vs. Drill Diameter (mm/rev)	
								Ø16 - Ø20.9	
P	Non-alloy steel and cast steel, free cutting steel	<0.25%C	Annealed	SS41/S10C	420	125	1	80-140	0.35-0.55
		>=0.25%C	Annealed	S25C	650	190	2	80-130	0.35-0.55
		<0.55%C	Quenched and tempered	S45C	850	250	3	80-120	0.35-0.55
		>=0.55%C	Annealed	S55C	750	220	4	70-110	0.35-0.55
			Quenched and tempered	SK3	1000	300	5	50-90	0.35-0.55
	Low alloy steel and cast steel (less than 5% of alloying elements)	Annealed	SCM4	600	200	6	80-120	0.30-0.50	
		Quenched and tempered	SKS3	930	275	7	70-110	0.30-0.50	
				1000	300	8	50-90	0.30-0.50	
				1200	350	9	40-70	0.30-0.50	
	High alloy steel, cast steel and tool steel	Annealed	SKD61	680	200	10	50-90	0.30-0.45	
		Quenched and tempered	SKH/HSS	1100	325	11	40-80	0.30-0.45	
K	Grey cast iron (GG)	Ferritic / pearlitic	FC		180	15	90-160	0.45-0.65	
		Pearlitic			260	16	80-140	0.45-0.65	
	Cast iron nodular (GGG)	Ferritic	FCD		160	17	90-180	0.40-0.60	
		Pearlitic			250	18	80-140	0.40-0.60	
	Malleable cast iron	Ferritic	FCMP/AC4A		130	19	90-160	0.40-0.60	
		Pearlitic			230	20	80-140	0.40-0.60	

■ Steel ■ Cast iron



## KIT COLLECTIONS

These kit products are available in the format listed below.



Cat. No.	Designation	Bill of materials	Qty.
6334407	<b>KISFT-3ED 160-P+5D TT5130</b>	3ED 160-169-20T3-5D	1
		3ED-160-P+ TT5130	3
6334408	<b>KISFT-3ED 170-P+5D TT5130</b>	3ED 170-179-20T3-5D	1
		3ED-170-P+ TT5130	3
6334409	<b>KISFT-3ED 180-P+5D TT5130</b>	3ED 180-189-25T2-5D	1
		3ED-180-P+ TT5130	3
6334410	<b>KISFT-3ED 190-P+5D TT5130</b>	3ED 190-199-25T2-5D	1
		3ED-190-P+ TT5130	3
6334411	<b>KISFT-3ED 200-P+5D TT5130</b>	3ED 200-209-25T2-5D	1
		3ED-200-P+ TT5130	3



Cat. No.	Designation	Bill of materials	Qty.
6334422	<b>KISFS-3ED 160-P+5D TT5130</b>	3ED 160-169-20T3-5D	1
		3ED-160-P+ TT5130	10
6334423	<b>KISFS-3ED 170-P+5D TT5130</b>	3ED 170-179-20T3-5D	1
		3ED-170-P+ TT5130	10
6334424	<b>KISFS-3ED 180-P+5D TT5130</b>	3ED 180-189-25T2-5D	1
		3ED-180-P+ TT5130	10
6334425	<b>KISFS-3ED 190-P+5D TT5130</b>	3ED 190-199-25T2-5D	1
		3ED-190-P+ TT5130	10
6334428	<b>KISFS-3ED 200-P+5D TT5130</b>	3ED 200-209-25T2-5D	1
		3ED-200-P+ TT5130	10



Cat. No.	Designation	Bill of materials	Qty.
6334442	<b>KISFF-3ED 160-P+ TT5130</b>	3ED-160-P+ TT5130	30
6334443	<b>KISFF-3ED 170-P+ TT5130</b>	3ED-170-P+ TT5130	30
6334444	<b>KISFF-3ED 180-P+ TT5130</b>	3ED-180-P+ TT5130	30
6334445	<b>KISFF-3ED 190-P+ TT5130</b>	3ED-190-P+ TT5130	30
6334446	<b>KISFF-3ED 200-P+ TT5130</b>	3ED-200-P+ TT5130	30